

~~~~~ Index ~~~~~

|                                                                                                                                |          |
|--------------------------------------------------------------------------------------------------------------------------------|----------|
| <b>1. SCOPE .....</b>                                                                                                          | <b>4</b> |
| <b>2. FEATURES.....</b>                                                                                                        | <b>4</b> |
| <b>3. PRECAUTIONS (OPERATING RECOMMENDATIONS) .....</b>                                                                        | <b>4</b> |
| <b>4. PRODUCT SPECIFICATIONS.....</b>                                                                                          | <b>5</b> |
| 4.1 Type .....                                                                                                                 | 5        |
| 4.2 Outer Dimensions, Weight.....                                                                                              | 5        |
| 4.3 Environment Conditions.....                                                                                                | 5        |
| 4.4 Absolute Maximum Ratings .....                                                                                             | 5        |
| 4.5 Recommend Operating Conditions .....                                                                                       | 5        |
| 4.6 DC Characteristics.....                                                                                                    | 5        |
| 4.7 Timing Chart .....                                                                                                         | 6        |
| 4.8 Interfacing Connectors .....                                                                                               | 6        |
| 4.9 System Block Diagram.....                                                                                                  | 6        |
| 4.10 Outer Dimensions.....                                                                                                     | 7        |
| 4.11 Pattern Details .....                                                                                                     | 7        |
| <b>5. FUNCTIONS .....</b>                                                                                                      | <b>8</b> |
| 5.1 Jumper Switches Setting.....                                                                                               | 8        |
| 5.2 Self-Test Function .....                                                                                                   | 8        |
| 5.2.1 Starting the Self-Test .....                                                                                             | 8        |
| 5.2.2 Ending the Self-Test .....                                                                                               | 8        |
| 5.2.3 Contents of the Self-Test .....                                                                                          | 8        |
| 5.3 Character Data Write-in.....                                                                                               | 9        |
| 5.4 Control Code Write-in .....                                                                                                | 9        |
| 5.4.1 BS (08 Hex): Move cursor left (Back Space).....                                                                          | 9        |
| 5.4.2 HT (09 Hex): Move cursor right (Horizontal Tab) .....                                                                    | 9        |
| 5.4.3 LF (0A Hex): Move cursor down (Line Feed).....                                                                           | 10       |
| 5.4.4 US LF (1F Hex + 0A Hex): Move cursor up .....                                                                            | 10       |
| 5.4.5 HOM (0B Hex): Move cursor to home position.....                                                                          | 10       |
| 5.4.6 CR (0D Hex): Move cursor to left-end position .....                                                                      | 10       |
| 5.4.7 US CR (1F Hex + 0D Hex): Move cursor to right-end position.....                                                          | 10       |
| 5.4.8 US B (1F Hex + 42 Hex): Move cursor to bottom position.....                                                              | 10       |
| 5.4.9 US \$ n m (1F Hex + 24 Hex + n + m): Move cursor to specified position.....                                              | 10       |
| 5.4.10 CLR (0C Hex): Clear display screen.....                                                                                 | 10       |
| 5.4.11 CAN (18 Hex): Clear cursor line.....                                                                                    | 10       |
| 5.4.12 Esc @ (1B Hex + 40 Hex): Initialize display .....                                                                       | 10       |
| 5.4.13 Esc % n (1B Hex + 25 Hex + n): Select/cancel user-defined font set .....                                                | 11       |
| 5.4.14 Esc & s n m a p1 ... ps (1B Hex + 26 Hex + s + n + m + [a+p1+p2+ ..., ps * a] m-n+1 ): Define user-definable font ..... | 11       |
| 5.4.15 Esc ? n (1B Hex + 3F Hex + n): Cancel user-defined fonts.....                                                           | 12       |
| 5.4.16 Esc R n (1B Hex + 52 Hex + n): Select an international character set .....                                              | 12       |
| 5.4.17 Esc = n (1B Hex + 3D Hex + n): Select / Cancel peripheral device.....                                                   | 13       |
| 5.4.18 Esc t n (1B Hex + 74 Hex + n): Select character code table (CG-ROM font from 80 Hex to FF Hex) .....                    | 13       |

---

|                                                                             |           |
|-----------------------------------------------------------------------------|-----------|
| 5.4.19 US MD1 (1F Hex + 01 Hex): Select overwrite mode .....                | 13        |
| 5.4.20 US MD2 (1F Hex + 02 Hex): Select vertical scroll mode.....           | 13        |
| 5.4.21 US MD3 (1F Hex + 03 Hex): Select horizontal scroll mode.....         | 14        |
| 5.4.22 US E n (1F Hex + 45 Hex + n): Set display screen blink interval..... | 14        |
| 5.4.23 US X n (1F Hex + 58 Hex + n): Brightness adjustment .....            | 14        |
| 5.4.24 US # n m (1F Hex + 23 Hex + n + m): Turn annunciator on/off .....    | 14        |
| 5.4.25 US @ (1F Hex + 40 Hex): Execute self-test .....                      | 14        |
| 5.5 Defaults (Initial States at Power-on).....                              | 14        |
| <b>6. CG-ROM Font (Character Code Table).....</b>                           | <b>15</b> |
| ASCII CODE: .....                                                           | 15        |
| 6.1 PC437 (Standard European).....                                          | 16        |
| 6.2 PC850 (Multilingual Latin I).....                                       | 16        |
| 6.3 PC866 (Cyrillic-2).....                                                 | 17        |
| 6.4 PC737 (Greek).....                                                      | 17        |
| 6.5 PC862 (Hebrew).....                                                     | 18        |
| 6.6 CP10 for DP86-20.....                                                   | 18        |
| 6.7 PC864 (Arabic).....                                                     | 19        |
| 6.8 PC852 (Multilingual Latin II) .....                                     | 19        |

## 1. SCOPE

This specification applies to VFD module (Model No. 20L203DA13) manufactured by SSED (Shanghai Samsung SVA Electronic Devices).

## 2. FEATURES

- \* High Quality, Attractive and Readable Display: 5\*7 Dot Matrix Type VFD
- \* Wide Operating Voltage (Free Voltage Input without any Jumper Settings): +5VDC ~ +24VDC
- \* Single Wired Interface; Asynchronous Serial (RS-232C), Baud-rate: 2400 ~ 19200 bps
- \* 8 kinds of CG-ROM Font: PC437, PC850, PC852, PC866, PC737, PC862, CP10 for DP86-20 and PC864
- \* Brightness Level: Four Levels (40%, 60%, 80% and 100%)

## 3. PRECAUTIONS (OPERATING RECOMMENDATIONS)

- \* Avoid applying excessive shock or vibration beyond the specification for the VFD module.
- \* Since VFD is made of glass material, careful handling is required. i.e. Direct impact with hard material to the glass surface(especially exhaust tip) may crack the glass.
- \* When mounting the VFD module to your system, leave a slight gap between the VFD glass and your front panel. The module should be mounted without stress to avoid flexing of the PCB.
- \* Avoid plugging or unplugging the interface connection with the power on, otherwise it may cause the severe damage to input circuitry.
- \* Exceeding any of maximum ratings may cause the permanent damage.
- \* Since the VFD modules contain high voltage source, careful handling is required during powered on.
- \* When the power is turned off, the capacitor does not discharge immediately. The high voltage applied to the VFD must not contact to the ICs. In other words, the compulsory short-circuit of mounted components on PCB within 30 seconds after power-off may cause damage to the module.
- \* The power supply must be capable of providing at least 5 times the rated current, because the inrush current maybe 5 times the specified current consumption when the power is turned on.
- \* Avoid using the module where excessive noise interference is expected. Noise may affects the interface signal and causes improper operation. And it is important to keep the length of the interface cable less than 15 meters (50 feet).
- \* Since all VFD modules contain C-MOS ICs, anti-static handling procedures are always required.

## 4. PRODUCT SPECIFICATIONS

### 4.1 Type

|              |                                   |
|--------------|-----------------------------------|
| Type         | 20L203DA13                        |
| Digit Format | 5 * 7 Dot Matrix with Annunciator |

### 4.2 Outer Dimensions, Weight

| Parameters       | Symbols   | Specification       | Unit |
|------------------|-----------|---------------------|------|
| Outer Dimensions | W * H * t | 190.0 * 64.0 * 24.6 | mm   |
| Glass Size       | W * H     | 175.2 * 48.3        | mm   |
| Display Area     | W * H     | 146.1 * 29.0        | mm   |
| Character Size   | W * H     | 5.5 * 10.5          | mm   |
| Character Pitch  | W * H     | 7.4 * 15.5          | mm   |
| Weight           |           | Approx. 200         | g    |

### 4.3 Environment Conditions

| Parameters               | Symbols          | Min. | Max. | Unit |
|--------------------------|------------------|------|------|------|
| Operating Temperature    | T <sub>OPR</sub> | -0   | +75  | °C   |
| Storage Temperature      | T <sub>STG</sub> | -40  | +85  | °C   |
| Humidity (Operating)     | H <sub>OPR</sub> | 30   | 85   | %    |
| Humidity (Non-operating) | H <sub>STG</sub> | 30   | 90   | %    |
| Vibration (10 ~ 55 Hz)   | -                | -    | 4    | G    |
| Shock                    | -                | -    | 40   | G    |

### 4.4 Absolute Maximum Ratings

| Parameters           | Symbols         | Min.  | Max.  | Unit            |
|----------------------|-----------------|-------|-------|-----------------|
| Supply Voltage       | V <sub>CC</sub> | -0.3  | +30.0 | V <sub>DC</sub> |
| Input Signal Voltage | V <sub>IN</sub> | -30.0 | +30.0 | V <sub>DC</sub> |

### 4.5 Recommend Operating Conditions

| Parameters           | Symbols         | Min.  | Typ.  | Max.  | Unit            |
|----------------------|-----------------|-------|-------|-------|-----------------|
| Supply Voltage       | V <sub>CC</sub> | 4.5   | -     | 26    | V <sub>DC</sub> |
| Input Signal Voltage | SPACE           | +3.0  | +12.0 | +15.0 | V <sub>DC</sub> |
|                      | MARK            | -15.0 | -12.0 | -3.0  | V <sub>DC</sub> |

### 4.6 DC Characteristics

| Parameters                                    | Test Conditions                       | Min.                           | Typ. | Max.  | Unit |
|-----------------------------------------------|---------------------------------------|--------------------------------|------|-------|------|
| Supply Current (*)<br>(When all dots are lit) | V <sub>CC</sub> = +5 V <sub>DC</sub>  | -                              | 800  | 1,200 | mA   |
|                                               | V <sub>CC</sub> = +12 V <sub>DC</sub> | -                              | 350  | 550   | mA   |
|                                               | V <sub>CC</sub> = +24 V <sub>DC</sub> | -                              | 200  | 300   | mA   |
| Input Signal Current                          | V <sub>IN</sub> = +12 V <sub>DC</sub> | -                              | -    | +3    | mA   |
|                                               | V <sub>IN</sub> = -12 V <sub>DC</sub> | -                              | -    | -3    | mA   |
| Brightness                                    | V <sub>CC</sub> = +5 V <sub>DC</sub>  | 60                             | 120  | -     | ft-L |
| Display Color                                 | -                                     | Blue-green (peak wave = 505nm) |      |       | -    |

(\*) Note-1; The inrush current can be 10 times the specified maximum supply current at power on.

4.7 Timing Chart

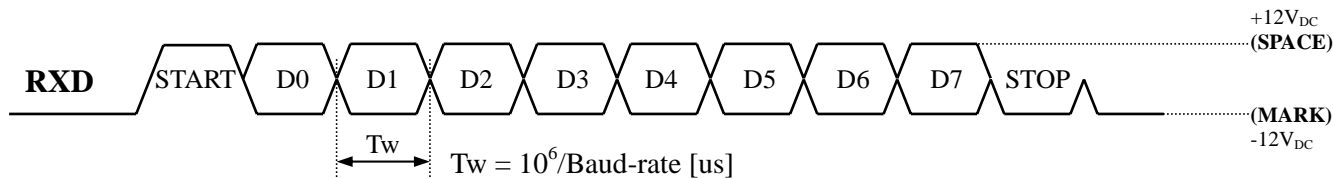
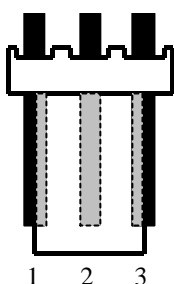

Fig.-1 Serial Input Timing Diagram (RXD input signal)

4.8 Interfacing Connectors

- \* Connector (Male): 5046-03A (by MOLEX) or equivalent - Single 3 Pins (Right Angled)
- Mate socket (Female): 5051-03 (by MOLEX) or equivalent



| Pin No. | Signal          |
|---------|-----------------|
| 1       | V <sub>CC</sub> |
| 2       | RXD             |
| 3       | GND             |

4.9 System Block Diagram

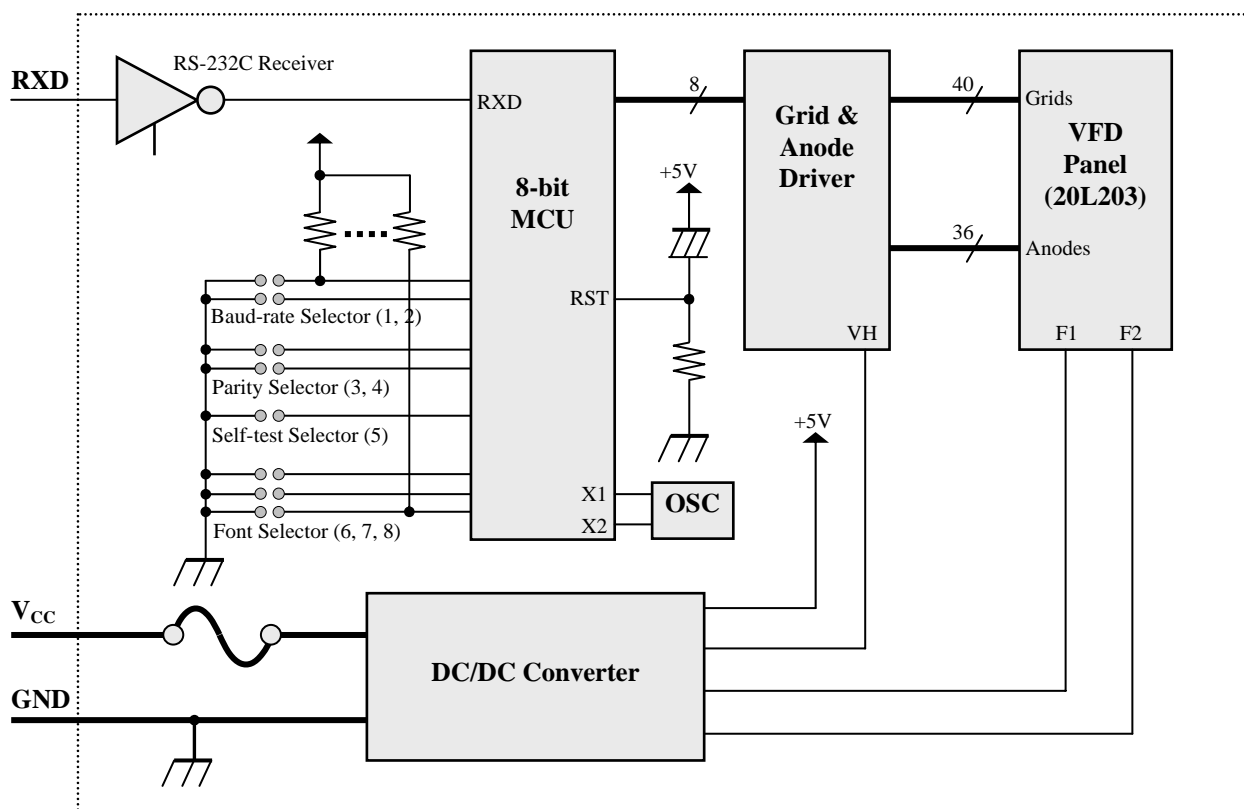

Fig.-2 System Block Diagram

4.10 Outer Dimensions

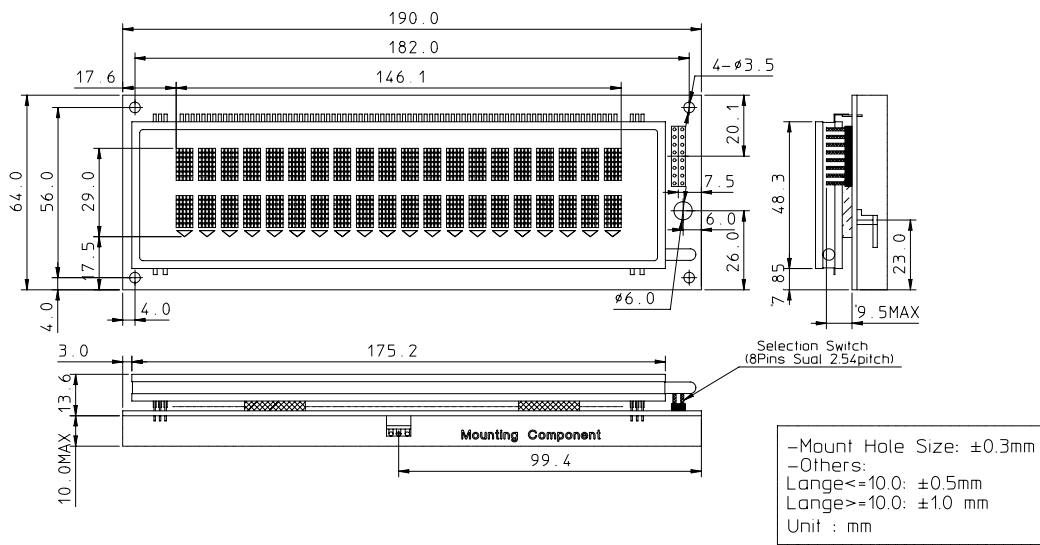

Fig.-3 outer Dimension

4.11 Pattern Details

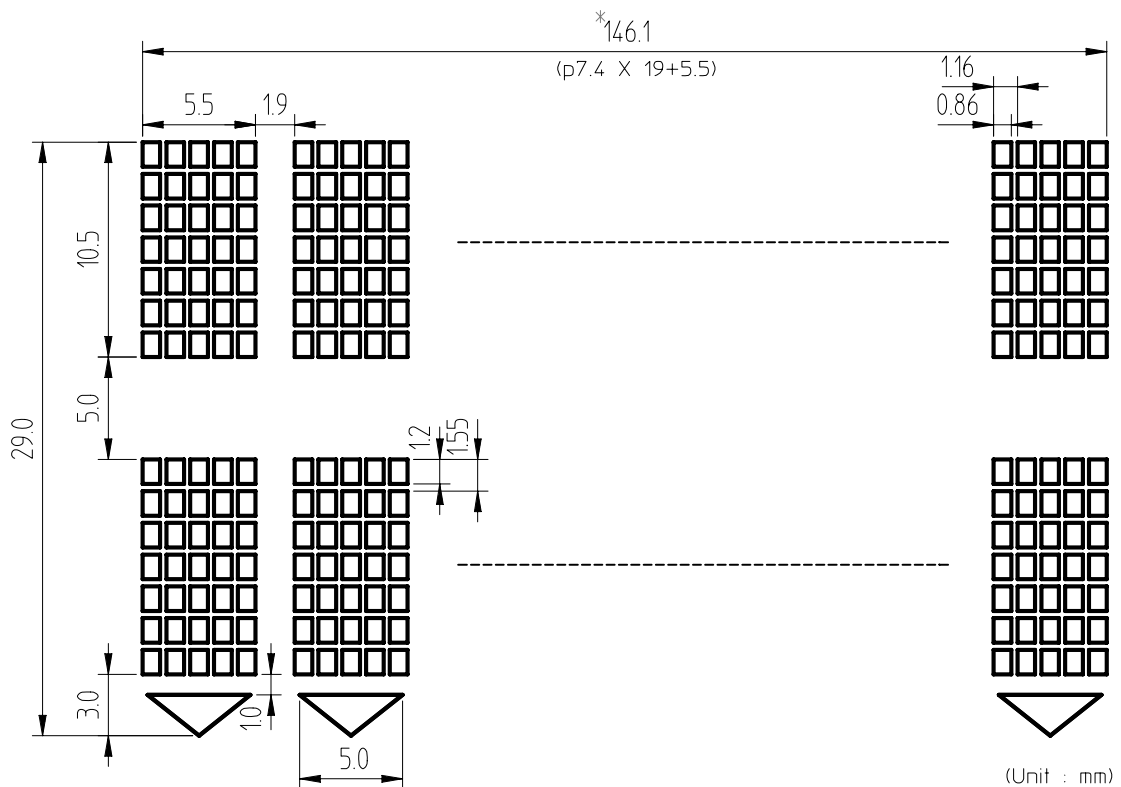

Fig.-4 Pattern Details

## 5. FUNCTIONS

### 5.1 Jumper Switches Setting

The jumper switches (2-rows and 8-lines pin headers) are located on the PCB's right side. (Refer to Fig.-3) The switch setting values are read only when the power is turned on. Therefore, changing the settings while the power is on has no effect.

**\* Jumper Switches OPEN/SHORT Function Table**

| 1                   | 2           | 3           | 4           | 5           | 6           | 7           | 8           | Setting Value             | Description                        |
|---------------------|-------------|-------------|-------------|-------------|-------------|-------------|-------------|---------------------------|------------------------------------|
| <b>Open</b>         | <b>Open</b> | X           | X           | X           | X           | X           | X           | <b>9,600 bps</b>          | Baud-rate Selection                |
| Open                | Short       | X           | X           | X           | X           | X           | X           | 4,800 bps                 |                                    |
| Short               | Open        | X           | X           | X           | X           | X           | X           | 2,400 bps                 |                                    |
| Short               | Short       | X           | X           | X           | X           | X           | X           | 19,200 bps                |                                    |
| X                   | X           | <b>Open</b> | X           | X           | X           | X           | X           | <b>Non Parity</b>         | Parity Selection                   |
| X                   | X           | Short       | <b>Open</b> | X           | X           | X           | X           | Odd Parity                |                                    |
| X                   | X           | Short       | Short       | X           | X           | X           | X           | Even Parity               |                                    |
| X                   | X           | X           | X           | <b>Open</b> | X           | X           | X           | <b>Normal Mode</b>        | Self-test Selection after power-on |
| X                   | X           | X           | X           | Short       | X           | X           | X           | Self-test Mode            |                                    |
| X                   | X           | X           | X           | X           | <b>Open</b> | <b>Open</b> | <b>Open</b> | <b>PC437</b>              | CG-ROM Font Selection              |
| X                   | X           | X           | X           | X           | Short       | Open        | Open        | PC850                     |                                    |
| X                   | X           | X           | X           | X           | Open        | Short       | Open        | PC866                     |                                    |
| X                   | X           | X           | X           | X           | Short       | Short       | Open        | PC737                     |                                    |
| X                   | X           | X           | X           | X           | Open        | Open        | Short       | PC862                     |                                    |
| X                   | X           | X           | X           | X           | Short       | Open        | Short       | CP10 for DP86-20          |                                    |
| X                   | X           | X           | X           | X           | Open        | Short       | Short       | PC864                     |                                    |
| X                   | X           | X           | X           | X           | Short       | Short       | Short       | PC852                     |                                    |
| <b>Open</b>         | <b>Open</b> | <b>Open</b> | <b>Open</b> | <b>Open</b> | <b>Open</b> | <b>Open</b> | <b>Open</b> | <b>Setting at Factory</b> |                                    |
| Note) X: Don't Care |             |             |             |             |             |             |             |                           |                                    |

### 5.2 Self-Test Function

The self-test operation will be executed for 20 seconds approximately. When the self-test is being executed, receiving data is not processed. Therefore, host computer should transmit the data after 20 seconds from the beginning of a self-test.

#### 5.2.1 Starting the Self-Test

There are two ways to start the self-test, as follows:

- 1) Use Control Commands (See Section 5.4.25)
- 2) Use Jumper switch (Switch #5 is to be short-circuited.)

#### 5.2.2 Ending the Self-Test

After a series of self-tests is executed, the screen is cleared, the cursor is moved to the home position, and the display goes into the standby state.

#### 5.2.3 Contents of the Self-Test

The self-test shows the following:

- 1) Selection switches state
- 2) Display characters
- 3) Functions

*Note 1) When the self-test is executed using command of "US @", the user-defined character definitions are retained.*

*Note 2) In using this mode, neither data nor control code write-in is allowed.*

### 5.3 Character Data Write-in

When the character data code (20 Hex ~ FF Hex) is written-in to the module, the corresponding character font is displayed on the screen. At this time, the cursor will be shifted to the right one digit automatically. (Please refer to the page-14 through page-19.)

### 5.4 Control Code Write-in

The following table shows control commands, and details are will be explained from section 5.4.1 to 5.4.25.

| No. | Symbol | Function                           | No. | Symbol | Function                              |
|-----|--------|------------------------------------|-----|--------|---------------------------------------|
| 1   | BS     | Move cursor left (Back Space)      | 14  | Esc &  | Define user-definable font            |
| 2   | HT     | Move cursor right (Horizontal Tab) | 15  | Esc ?  | Cancel user-defined font              |
| 3   | LF     | Move cursor down (Line Feed)       | 16  | Esc =  | Select peripheral device              |
| 4   | US LF  | Move cursor up                     | 17  | Esc R  | Select an international character set |
| 5   | HOM    | Move cursor to home position       | 18  | Esc t  | Select character code table           |
| 6   | CR     | Move cursor to left-end position   | 19  | US MD1 | Specify overwrite mode                |
| 7   | US CR  | Move cursor to right-end position  | 20  | US MD2 | Specify vertical scroll mode          |
| 8   | US B   | Move cursor to bottom position     | 21  | US MD3 | Specify horizontal scroll mode        |
| 9   | US \$  | Move cursor to specified position  | 22  | US E   | Select/Cancel display screen blinking |
| 10  | CLR    | Clear display screen               | 23  | US X   | Brightness adjustment (Dimming)       |
| 11  | CAN    | Clear cursor line                  | 24  | US #   | Turn annunciator on/off               |
| 12  | Esc @  | Initialize display                 | 25  | US @   | Execute self-test                     |
| 13  | Esc %  | Select/Cancel user-defined font    |     |        |                                       |

#### 5.4.1 BS (08 Hex): Move cursor left (Back Space)

Move the cursor one character position to the left.

When the cursor is at the left end of one line, the operation of this command depends on the display mode.

1) Overwrite mode: When the cursor is at the left end of the lower line, it is moved to the right end of the upper line. When it is at the left end of the upper line, it is moved to the right end of the lower line.

2) Vertical scroll mode: When the cursor is at the left end of the lower line, it is moved to the right end of the upper line. When it is at the left end of the upper line, the display on the upper line is scrolled to the lower line and the upper line is cleared. At this time the cursor is moved to the right end of the upper line.

3) Horizontal scroll mode: All characters on the current line are scrolled on character to the right horizontally. The cursor is not moved, but the character area at the left end is cleared.

#### 5.4.2 HT (09 Hex): Move cursor right (Horizontal Tab)

Move the cursor one character-position to the right.

When the cursor is at the right end of a line, the operation of this command depends on the display mode.

1) Overwrite mode: When the cursor is at the right end of the upper line, it is moved to the left end of the lower line. When it is at the right end of the lower line, it is moved to the left end of the upper line.

2) Vertical scroll mode: When the cursor is at the right end of the upper line, it is moved to the left end of the lower line. When it is at the right end of the lower line, the display on the lower line is scrolled to the upper line and the lower line is cleared. At this time, the cursor is moved to the left end of the lower line.

3) Horizontal scroll line: All characters on the current line are scrolled one character to the left horizontally. The cursor is not moved, but the character area at the right end is cleared.



**5.4.3 LF (0A Hex): Move cursor down (Line Feed)**

Move the cursor down one line.

When the cursor is on the lower line, the operation of this command depends on the display mode, as follows:

- 1) Overwrite mode: The cursor is moved to the same column on the upper line.
- 2) Vertical scroll mode: The characters displayed in the lower line are scrolled to the upper line and the lower line is cleared. The cursor remains at the same position.
- 3) Horizontal scroll mode: The cursor is not moved.

**5.4.4 US LF (1F Hex + 0A Hex): Move cursor up**

Move the cursor up one line.

When the cursor is on the upper line, the operation of this command depends on the display mode, as follows:

- 1) Overwrite mode: The cursor is moved to the same column on the lower line.
- 2) Vertical scroll mode: The characters displayed on the upper line are scrolled to the lower line and the upper line is cleared. The cursor remains at the same position.
- 3) Horizontal scroll mode: The cursor is not moved.

**5.4.5 HOM (0B Hex): Move cursor to home position**

Move the cursor to the left-end position on the upper line (home position). Home position indicates the first column of the upper line.

**5.4.6 CR (0D Hex): Move cursor to left-end position**

Move the cursor to the left-end position on the current line.

**5.4.7 US CR (1F Hex + 0D Hex): Move cursor to right-end position**

Move the cursor to the right-end position on the current line.

**5.4.8 US B (1F Hex + 42 Hex): Move cursor to bottom position**

Move the cursor to the 20th column of the lower line.

**5.4.9 US \$ n m (1F Hex + 24 Hex + n + m): Move cursor to specified position**

*[Range] 01 Hex ≤ n ≤ 14 Hex (20 Decimal), m = 1 or 2*

Move the cursor to the *n*th column on the *m*th line. If a value exceeding the range is specified for *n*(column) and/or *m*(line), this command is ignored and the cursor does not move.

**5.4.10 CLR (0C Hex): Clear display screen**

Clear all the displayed characters.

After this command is executed, the cursor moves to the home position.

**5.4.11 CAN (18 Hex): Clear cursor line**

Clear the line containing the cursor.

After this command is executed, the cursor moves to the left-end position on the current line.

**5.4.12 Esc @ (1B Hex + 40 Hex): Initialize display**

Reset the various display settings to their initial values.

The software settings are reset to their power-on values. The soldering land switches are not checked again except font selector switches #6, #7 and #8.

After initializing the display, the display screen is cleared and the cursor moves to the home position.

**5.4.13 Esc % n (1B Hex + 25 Hex + n): Select/cancel user-defined font set**

[Range]  $n = 0$  or  $1$

Select or cancel the user-defined font set.

When  $n = 1$ , the user-defined font set is selected. When the user-defined character set is not defined using the **Esc &** command, the international character set is displayed.

When  $n = 0$ , the user-defined font set is canceled. (The international character set is selected.) In this case, this command has no effect on the user-defined font that have already been defined using the **Esc &** command. This command has no effect on the characters already displayed.

**5.4.14 Esc & s n m a p1 ... ps (1B Hex + 26 Hex + s + n + m + [a+p1+p2+ ..., ps \* a] m-n+1 ): Define user-definable font**

[Range]  $s = 1$

$20 \text{ Hex} \leq n \leq m \leq 7E \text{ Hex}$

$0 \leq a \leq 5$

$00 \text{ Hex} \leq p_1, \dots, p_s * a \leq FF \text{ Hex}$

's' denotes the number of bytes in the vertical direction.

'n' specifies the beginning character code for the direction, and 'm' the final character code. When only one character is defined, use  $n=m$ .

4 characters can be defined between character codes 20 Hex and 7E Hex in the character code table.

'a' denotes the number of dots in the horizontal direction.

When 'a' < 5, the remaining dots on the right side of the user-defined characters are padded with spaces.

$p_1 \dots p_s$  is the dot data to be defined for the characters. The dot pattern is in the horizontal direction from the left side. The number of data items to be defined is specified for the communication word length, the most significant bit is ignored.

Once the user-defined characters are defined they remain effective until they are redefined, Esc @ is executed, or the power is turn off.

When only the user-defined character definition is set and user-defined character set is not selected using Esc % command, user-defined characters are not displayed.

[Example] To define the character "\$" at character code 20H :

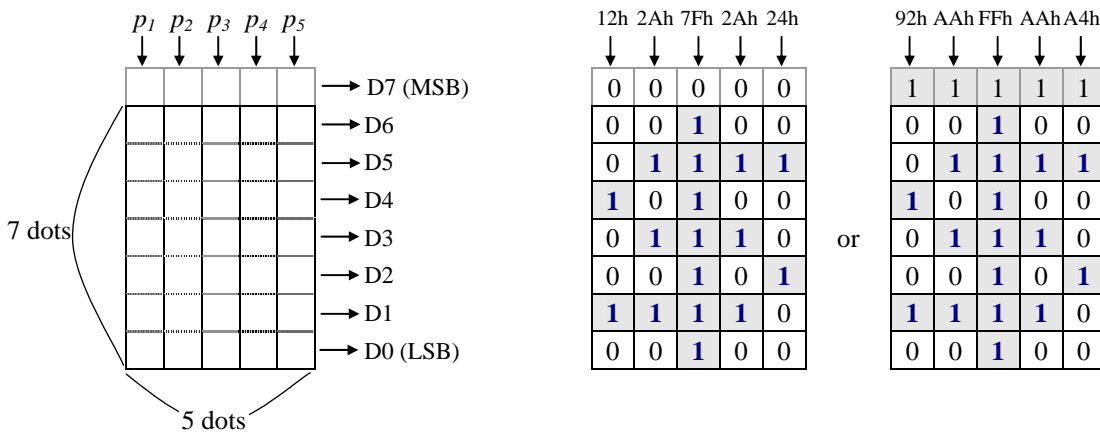

1) When the most significant bit is processed as "0", or when the communication word length is specified as seven bits, the defined character definition is executed as shown below:

[1BH] [26H] [01H]: define user-definable character

[20H] [20H] [05H]: code from 20H to 20H, each character will be composed by 5 bytes

[12H] [2AH] [7FH] [2AH] [24H]: left side of above define example (MSB="0")

2) When the communication word length is specified as eight bits and the most significant bit is processed as "1", the user-defined character definition is executed as shown below:

- [1BH] [26H] [01H]: define user-defined character
- [20H] [20H] [05H]: code from 20H to 20H, each character will be composed by 5 bytes
- [92H] [AAH] [FFH] [AAH] [A4H]: right side of above define example (MSB="1")

**5.4.15 Esc ? n (1B Hex + 3F Hex + n): Cancel user-defined fonts**

[Range] 20 Hex ≤ n ≤ 7E Hex

Cancel user-defined fonts.

This command cancels the pattern defined for the character code specified by the 3rd byte(n). If the specified code is transmitted after the pattern is canceled by this command, the international character is displayed. If the specified character code is not defined, this command is ignored. This command has no effect on characters already displayed.

**5.4.16 Esc R n (1B Hex + 52 Hex + n): Select an international character set**

[Range] 0 ≤ n ≤ 0A Hex

When the power is turned on 'n' is set to 0 (U.S.A).

| n  | Country   | 35  | 36  | 64  | 91  | 92  | 93  | 94  | 96  | 123 | 124 | 125 | 126 |
|----|-----------|-----|-----|-----|-----|-----|-----|-----|-----|-----|-----|-----|-----|
|    |           | 23h | 24h | 40h | 5Bh | 5Ch | 5Dh | 5Eh | 60h | 7Bh | 7Ch | 7Dh | 7Eh |
| 0  | U.S.A     |     |     |     |     |     |     |     |     |     |     |     |     |
| 1  | FRANCE    |     |     |     |     |     |     |     |     |     |     |     |     |
| 2  | GERMANY   |     |     |     |     |     |     |     |     |     |     |     |     |
| 3  | U.K.      |     |     |     |     |     |     |     |     |     |     |     |     |
| 4  | DENMARK 1 |     |     |     |     |     |     |     |     |     |     |     |     |
| 5  | SWEDEN    |     |     |     |     |     |     |     |     |     |     |     |     |
| 6  | ITALY     |     |     |     |     |     |     |     |     |     |     |     |     |
| 7  | SPAIN 1   |     |     |     |     |     |     |     |     |     |     |     |     |
| 8  | JAPAN     |     |     |     |     |     |     |     |     |     |     |     |     |
| 9  | NORWAY    |     |     |     |     |     |     |     |     |     |     |     |     |
| 10 | DENMARK 2 |     |     |     |     |     |     |     |     |     |     |     |     |

**5.4.17 Esc = n (1B Hex + 3D Hex + n): Select / Cancel peripheral device****[Range]**  $1 \leq n \leq 3$ Selects or cancels VFD device, in accordance with the value of  $n$ . $n = 1$ : This VFD Module is canceled. $n = 2$ : This VFD Module is selected. (Default) $n = 3$ : This VFD Module and the other device are selected.

This Command is effectively applied that the data from the host is transmitted to the other device via the VFD module.

[Example: Data lines are used in common with printer.]

| Data bit | Peripheral Device | 1        | 0        |
|----------|-------------------|----------|----------|
| D0       | Printer           | Selected | Canceled |
| D1       | VFD Module        | Selected | Canceled |
| D2 ~ D7  | Undefined         | *        | *        |

- \* When the printer is selected by  $n = 1$ , all the data from the host computer is transmitted to the printer via the VFD Module.
- \* When the VFD Module is selected by  $n = 2$ , all the data from the host computer is processed internally in the VFD Module, and no data is transmitted to the printer.
- \* When both the printer and VFD Module are selected by  $n = 3$ , all the data from the host computer is processed internally in the VFD Module and transmitted to the printer simultaneously.

**5.4.18 Esc t n (1B Hex + 74 Hex + n): Select character code table (CG-ROM font from 80 Hex to FF Hex)****[Range]**  $0 \leq n \leq 7$ 

Select a character code table.

When  $n = 0$ , the PC437 is selected.When  $n = 1$ , the PC850 is selected.When  $n = 2$ , the PC866 is selected.When  $n = 3$ , the PC737 is selected.When  $n = 4$ , the PC862 is selected.When  $n = 5$ , the CP10 for DP86-20 is selected.When  $n = 6$ , the PC864 is selected.When  $n = 7$ , the PC852 is selected

This command has no effect on data displayed before this command is received.

This command has no effect on the selected international character set.

When the power is turned on, the  $n$  depends on the jumper selection switches (pin header #6, #7 and #8).**5.4.19 US MD1 (1F Hex + 01 Hex): Select overwrite mode**

Select overwrite mode as the screen display mode.

In overwriting mode, entering a character code moves to the left end of the lower line when the cursor is at the right end of the upper line, and to the left end of the upper line when the cursor is at the right end of the lower line. When the power is turned on, this mode is selected default.

**5.4.20 US MD2 (1F Hex + 02 Hex): Select vertical scroll mode**

Select vertical scroll mode as the screen display mode.

In vertical scroll mode, entering a character code moves the cursor to the left end of the lower line when the cursor is at the right end of the upper line, scrolls the characters displayed on the lower line, and clears the lower line when the cursor is at the right end of the lower line. At this time the cursor is moved to the left end of the lower line.

**5.4.21 US MD3 (1F Hex + 03 Hex): Select horizontal scroll mode**

Select vertical scroll mode as the screen display mode.

In horizontal scroll mode, entering a character code scrolls all displayed characters one character to the left, then displays the new character at the right end when the cursor is at the right end of either line.

**5.4.22 US E n (1F Hex + 45 Hex + n): Set display screen blink interval**

*[Range]*  $0 \leq n \leq FF \text{ Hex}$

Set or cancel the blinking intervals of the display screen.

$n$  specifies the blink interval. [ $n * 13$  milliseconds) ON + ( $n * 13$  milliseconds) OFF] is repeated.

When  $n = 0$ , the display is kept on (cancels blinking).

When  $n = FF \text{ Hex}$  (255 decimal), the display is turned off but the contents of the display are maintained. When the power is turned on,  $n = 0$  is selected.

**5.4.23 US X n (1F Hex + 58 Hex + n): Brightness adjustment**

*[Range]*  $1 \leq n \leq 4$

Set the brightness of the vacuum fluorescent character display tube.

$n$  selects the percentage of brightness as follows:

$n = 1$ , Brightness Level = 40 %

$n = 2$ , Brightness Level = 60 %

$n = 3$ , Brightness Level = 80 %

$n = 4$ , Brightness Level = 100 %

When the power is turned on,  $n = 4$  is selected.

**5.4.24 US # n m (1F Hex + 23 Hex + n + m): Turn annunciator on/off**

*[Range]*  $n=0 \text{ or } 1, 0 \leq m \leq 14 \text{ Hex}$

Turn the annunciator at column  $m$  on or off.

When  $n = 0$ , the annunciator at column  $m$  is turned off.

When  $n = 1$ , the annunciator at column  $m$  is turned on.

$m$  specifies the column number (the left-end column is column 1) where the annunciator to be turned on or off is located. However, when  $m$  equals 0, all annunciators are either off or on, based on the corresponding value of  $n$ .

**5.4.25 US @ (1F Hex + 40 Hex): Execute self-test**

Execute the self-test. A series of self-tests is displayed. All set values except user-defined character definitions are initialized. After a series of self-tests is executed, the screen is cleared and the display position is moved to the home position.

**5.5 Defaults (Initial States at Power-on)**

The following table shows the default setting values at the time power is turned-on.

| No. | Items                       | Setting Value                               |
|-----|-----------------------------|---------------------------------------------|
| 1   | Display Device Select       | Selected                                    |
| 2   | Display Mode                | Overwrite Mode (US MD1)                     |
| 3   | Cursor position             | Home Position (Left-end of Upper row)       |
| 4   | Display condition           | Clear screen                                |
| 5   | Character code table        | Depend on the Selection switches 6, 7 and 8 |
| 6   | International character set | U.S.A.                                      |
| 7   | User-defined characters     | Not defined                                 |
| 8   | Screen Blinking             | Canceled                                    |
| 9   | Brightness                  | 100%                                        |

### 6. CG-ROM Font (Character Code Table)

CG-ROM fonts are composed of ASCII (20h~7Fh) and optional font (80h~FFh). The 12 character codes in ASCII area can be set to international character code by using 'Esc R n' command (refer to the section 5.4.16 in page-12).

In case of optional font, it will be set by jumper switch #6, #7 and #8 when the power is turned-on. A user can change the optional CG-ROM font table by using 'Esc t n' command after power on (refer to the section 5.4.18 in page-13).

**ASCII CODE:**

|     | 0                                         | 1                                         | 2                                         | 3                                         | 4                                         | 5                                         | 6                                         | 7                                         | 8                                         | 9                                         | A                                         | B                                         | C                                         | D                                         | E                                         | F                                         |                                           |
|-----|-------------------------------------------|-------------------------------------------|-------------------------------------------|-------------------------------------------|-------------------------------------------|-------------------------------------------|-------------------------------------------|-------------------------------------------|-------------------------------------------|-------------------------------------------|-------------------------------------------|-------------------------------------------|-------------------------------------------|-------------------------------------------|-------------------------------------------|-------------------------------------------|-------------------------------------------|
| 20H | .....<br>.....<br>.....<br>.....<br>..... | .....<br>.....<br>.....<br>.....<br>..... | .....<br>.....<br>.....<br>.....<br>..... | .....<br>.....<br>.....<br>.....<br>..... | .....<br>.....<br>.....<br>.....<br>..... | .....<br>.....<br>.....<br>.....<br>..... | .....<br>.....<br>.....<br>.....<br>..... | .....<br>.....<br>.....<br>.....<br>..... | .....<br>.....<br>.....<br>.....<br>..... | .....<br>.....<br>.....<br>.....<br>..... | .....<br>.....<br>.....<br>.....<br>..... | .....<br>.....<br>.....<br>.....<br>..... | .....<br>.....<br>.....<br>.....<br>..... | .....<br>.....<br>.....<br>.....<br>..... | .....<br>.....<br>.....<br>.....<br>..... | .....<br>.....<br>.....<br>.....<br>..... | .....<br>.....<br>.....<br>.....<br>..... |
| 30H | .....<br>.....<br>.....<br>.....<br>..... | .....<br>.....<br>.....<br>.....<br>..... | .....<br>.....<br>.....<br>.....<br>..... | .....<br>.....<br>.....<br>.....<br>..... | .....<br>.....<br>.....<br>.....<br>..... | .....<br>.....<br>.....<br>.....<br>..... | .....<br>.....<br>.....<br>.....<br>..... | .....<br>.....<br>.....<br>.....<br>..... | .....<br>.....<br>.....<br>.....<br>..... | .....<br>.....<br>.....<br>.....<br>..... | .....<br>.....<br>.....<br>.....<br>..... | .....<br>.....<br>.....<br>.....<br>..... | .....<br>.....<br>.....<br>.....<br>..... | .....<br>.....<br>.....<br>.....<br>..... | .....<br>.....<br>.....<br>.....<br>..... | .....<br>.....<br>.....<br>.....<br>..... | .....<br>.....<br>.....<br>.....<br>..... |
| 40H | .....<br>.....<br>.....<br>.....<br>..... | .....<br>.....<br>.....<br>.....<br>..... | .....<br>.....<br>.....<br>.....<br>..... | .....<br>.....<br>.....<br>.....<br>..... | .....<br>.....<br>.....<br>.....<br>..... | .....<br>.....<br>.....<br>.....<br>..... | .....<br>.....<br>.....<br>.....<br>..... | .....<br>.....<br>.....<br>.....<br>..... | .....<br>.....<br>.....<br>.....<br>..... | .....<br>.....<br>.....<br>.....<br>..... | .....<br>.....<br>.....<br>.....<br>..... | .....<br>.....<br>.....<br>.....<br>..... | .....<br>.....<br>.....<br>.....<br>..... | .....<br>.....<br>.....<br>.....<br>..... | .....<br>.....<br>.....<br>.....<br>..... | .....<br>.....<br>.....<br>.....<br>..... | .....<br>.....<br>.....<br>.....<br>..... |
| 50H | .....<br>.....<br>.....<br>.....<br>..... | .....<br>.....<br>.....<br>.....<br>..... | .....<br>.....<br>.....<br>.....<br>..... | .....<br>.....<br>.....<br>.....<br>..... | .....<br>.....<br>.....<br>.....<br>..... | .....<br>.....<br>.....<br>.....<br>..... | .....<br>.....<br>.....<br>.....<br>..... | .....<br>.....<br>.....<br>.....<br>..... | .....<br>.....<br>.....<br>.....<br>..... | .....<br>.....<br>.....<br>.....<br>..... | .....<br>.....<br>.....<br>.....<br>..... | .....<br>.....<br>.....<br>.....<br>..... | .....<br>.....<br>.....<br>.....<br>..... | .....<br>.....<br>.....<br>.....<br>..... | .....<br>.....<br>.....<br>.....<br>..... | .....<br>.....<br>.....<br>.....<br>..... | .....<br>.....<br>.....<br>.....<br>..... |
| 60H | .....<br>.....<br>.....<br>.....<br>..... | .....<br>.....<br>.....<br>.....<br>..... | .....<br>.....<br>.....<br>.....<br>..... | .....<br>.....<br>.....<br>.....<br>..... | .....<br>.....<br>.....<br>.....<br>..... | .....<br>.....<br>.....<br>.....<br>..... | .....<br>.....<br>.....<br>.....<br>..... | .....<br>.....<br>.....<br>.....<br>..... | .....<br>.....<br>.....<br>.....<br>..... | .....<br>.....<br>.....<br>.....<br>..... | .....<br>.....<br>.....<br>.....<br>..... | .....<br>.....<br>.....<br>.....<br>..... | .....<br>.....<br>.....<br>.....<br>..... | .....<br>.....<br>.....<br>.....<br>..... | .....<br>.....<br>.....<br>.....<br>..... | .....<br>.....<br>.....<br>.....<br>..... | .....<br>.....<br>.....<br>.....<br>..... |
| 70H | .....<br>.....<br>.....<br>.....<br>..... | .....<br>.....<br>.....<br>.....<br>..... | .....<br>.....<br>.....<br>.....<br>..... | .....<br>.....<br>.....<br>.....<br>..... | .....<br>.....<br>.....<br>.....<br>..... | .....<br>.....<br>.....<br>.....<br>..... | .....<br>.....<br>.....<br>.....<br>..... | .....<br>.....<br>.....<br>.....<br>..... | .....<br>.....<br>.....<br>.....<br>..... | .....<br>.....<br>.....<br>.....<br>..... | .....<br>.....<br>.....<br>.....<br>..... | .....<br>.....<br>.....<br>.....<br>..... | .....<br>.....<br>.....<br>.....<br>..... | .....<br>.....<br>.....<br>.....<br>..... | .....<br>.....<br>.....<br>.....<br>..... | .....<br>.....<br>.....<br>.....<br>..... | .....<br>.....<br>.....<br>.....<br>..... |

6.1 PC437 (Standard European)

|     | 0 | 1 | 2 | 3 | 4 | 5 | 6 | 7 | 8 | 9 | A | B | C | D | E | F |
|-----|---|---|---|---|---|---|---|---|---|---|---|---|---|---|---|---|
| 80H |   |   |   |   |   |   |   |   |   |   |   |   |   |   |   |   |
| 90H |   |   |   |   |   |   |   |   |   |   |   |   |   |   |   |   |
| A0H |   |   |   |   |   |   |   |   |   |   |   |   |   |   |   |   |
| B0H |   |   |   |   |   |   |   |   |   |   |   |   |   |   |   |   |
| C0H |   |   |   |   |   |   |   |   |   |   |   |   |   |   |   |   |
| D0H |   |   |   |   |   |   |   |   |   |   |   |   |   |   |   |   |
| E0H |   |   |   |   |   |   |   |   |   |   |   |   |   |   |   |   |
| F0H |   |   |   |   |   |   |   |   |   |   |   |   |   |   |   |   |

6.2 PC850 (Multilingual Latin I)

|     | 0 | 1 | 2 | 3 | 4 | 5 | 6 | 7 | 8 | 9 | A | B | C | D | E | F |
|-----|---|---|---|---|---|---|---|---|---|---|---|---|---|---|---|---|
| 80H |   |   |   |   |   |   |   |   |   |   |   |   |   |   |   |   |
| 90H |   |   |   |   |   |   |   |   |   |   |   |   |   |   |   |   |
| A0H |   |   |   |   |   |   |   |   |   |   |   |   |   |   |   |   |
| B0H |   |   |   |   |   |   |   |   |   |   |   |   |   |   |   |   |
| C0H |   |   |   |   |   |   |   |   |   |   |   |   |   |   |   |   |
| D0H |   |   |   |   |   |   |   |   |   |   |   |   |   |   |   |   |
| E0H |   |   |   |   |   |   |   |   |   |   |   |   |   |   |   |   |
| F0H |   |   |   |   |   |   |   |   |   |   |   |   |   |   |   |   |

6.3 PC866 (Cyrillic-2)

|     | 0 | 1 | 2 | 3 | 4 | 5 | 6 | 7 | 8 | 9 | A | B | C | D | E | F |
|-----|---|---|---|---|---|---|---|---|---|---|---|---|---|---|---|---|
| 80H |   |   |   |   |   |   |   |   |   |   |   |   |   |   |   |   |
| 90H |   |   |   |   |   |   |   |   |   |   |   |   |   |   |   |   |
| A0H |   |   |   |   |   |   |   |   |   |   |   |   |   |   |   |   |
| B0H |   |   |   |   |   |   |   |   |   |   |   |   |   |   |   |   |
| C0H |   |   |   |   |   |   |   |   |   |   |   |   |   |   |   |   |
| D0H |   |   |   |   |   |   |   |   |   |   |   |   |   |   |   |   |
| E0H |   |   |   |   |   |   |   |   |   |   |   |   |   |   |   |   |
| F0H |   |   |   |   |   |   |   |   |   |   |   |   |   |   |   |   |

6.4 PC737 (Greek)

|     | 0 | 1 | 2 | 3 | 4 | 5 | 6 | 7 | 8 | 9 | A | B | C | D | E | F |
|-----|---|---|---|---|---|---|---|---|---|---|---|---|---|---|---|---|
| 80H |   |   |   |   |   |   |   |   |   |   |   |   |   |   |   |   |
| 90H |   |   |   |   |   |   |   |   |   |   |   |   |   |   |   |   |
| A0H |   |   |   |   |   |   |   |   |   |   |   |   |   |   |   |   |
| B0H |   |   |   |   |   |   |   |   |   |   |   |   |   |   |   |   |
| C0H |   |   |   |   |   |   |   |   |   |   |   |   |   |   |   |   |
| D0H |   |   |   |   |   |   |   |   |   |   |   |   |   |   |   |   |
| E0H |   |   |   |   |   |   |   |   |   |   |   |   |   |   |   |   |
| F0H |   |   |   |   |   |   |   |   |   |   |   |   |   |   |   |   |



6.5 PC862 (Hebrew)

|     | 0 | 1 | 2 | 3 | 4 | 5 | 6 | 7 | 8 | 9 | A | B | C | D | E | F |
|-----|---|---|---|---|---|---|---|---|---|---|---|---|---|---|---|---|
| 80H |   |   |   |   |   |   |   |   |   |   |   |   |   |   |   |   |
| 90H |   |   |   |   |   |   |   |   |   |   |   |   |   |   |   |   |
| A0H |   |   |   |   |   |   |   |   |   |   |   |   |   |   |   |   |
| B0H |   |   |   |   |   |   |   |   |   |   |   |   |   |   |   |   |
| C0H |   |   |   |   |   |   |   |   |   |   |   |   |   |   |   |   |
| D0H |   |   |   |   |   |   |   |   |   |   |   |   |   |   |   |   |
| E0H |   |   |   |   |   |   |   |   |   |   |   |   |   |   |   |   |
| F0H |   |   |   |   |   |   |   |   |   |   |   |   |   |   |   |   |

6.6 CP10 for DP86-20

|     | 0 | 1 | 2 | 3 | 4 | 5 | 6 | 7 | 8 | 9 | A | B | C | D | E | F |
|-----|---|---|---|---|---|---|---|---|---|---|---|---|---|---|---|---|
| 80H |   |   |   |   |   |   |   |   |   |   |   |   |   |   |   |   |
| 90H |   |   |   |   |   |   |   |   |   |   |   |   |   |   |   |   |
| A0H |   |   |   |   |   |   |   |   |   |   |   |   |   |   |   |   |
| B0H |   |   |   |   |   |   |   |   |   |   |   |   |   |   |   |   |
| C0H |   |   |   |   |   |   |   |   |   |   |   |   |   |   |   |   |
| D0H |   |   |   |   |   |   |   |   |   |   |   |   |   |   |   |   |
| E0H |   |   |   |   |   |   |   |   |   |   |   |   |   |   |   |   |
| F0H |   |   |   |   |   |   |   |   |   |   |   |   |   |   |   |   |

6.7 PC864 (Arabic)

|     | 0 | 1 | 2 | 3 | 4 | 5 | 6 | 7 | 8 | 9 | A | B | C | D | E | F |
|-----|---|---|---|---|---|---|---|---|---|---|---|---|---|---|---|---|
| 80H |   |   |   |   |   |   |   |   |   |   |   |   |   |   |   |   |
| 90H |   |   |   |   |   |   |   |   |   |   |   |   |   |   |   |   |
| A0H |   |   |   |   |   |   |   |   |   |   |   |   |   |   |   |   |
| B0H |   |   |   |   |   |   |   |   |   |   |   |   |   |   |   |   |
| C0H |   |   |   |   |   |   |   |   |   |   |   |   |   |   |   |   |
| D0H |   |   |   |   |   |   |   |   |   |   |   |   |   |   |   |   |
| E0H |   |   |   |   |   |   |   |   |   |   |   |   |   |   |   |   |
| F0H |   |   |   |   |   |   |   |   |   |   |   |   |   |   |   |   |

6.8 PC852 (Multilingual Latin II)

|     | 0 | 1 | 2 | 3 | 4 | 5 | 6 | 7 | 8 | 9 | A | B | C | D | E | F |
|-----|---|---|---|---|---|---|---|---|---|---|---|---|---|---|---|---|
| 80H |   |   |   |   |   |   |   |   |   |   |   |   |   |   |   |   |
| 90H |   |   |   |   |   |   |   |   |   |   |   |   |   |   |   |   |
| A0H |   |   |   |   |   |   |   |   |   |   |   |   |   |   |   |   |
| B0H |   |   |   |   |   |   |   |   |   |   |   |   |   |   |   |   |
| C0H |   |   |   |   |   |   |   |   |   |   |   |   |   |   |   |   |
| D0H |   |   |   |   |   |   |   |   |   |   |   |   |   |   |   |   |
| E0H |   |   |   |   |   |   |   |   |   |   |   |   |   |   |   |   |
| F0H |   |   |   |   |   |   |   |   |   |   |   |   |   |   |   |   |